

# Compilation Methods

Prof. Dr. Uwe Kastens

Summer 2013

## 1 Introduction

### Objectives

The students are going to learn

- what the main tasks of the **synthesis part of optimizing compilers** are,
- how **data structures and algorithms** solve these tasks systematically,
- what can be achieved by **program analysis and optimizing transformations**,

### Prerequisites

- Constructs and properties of programming languages
- What does a compiler know about a program?
- How is that information represented?
- Algorithms and data structures of the analysis parts of compilers (frontends)

Main aspects of the lecture ***Programming Languages and Compilers*** (PLaC, BSc program)  
<http://ag-kastens.upb.de/lehre/material/plac>

## Syllabus

Week	Chapter	Topic
1	1 Introduction	Compiler structure
	2 Optimization	Overview: Data structures, program transformations
2		Control-flow analysis
3		Loop optimization
4, 5		Data-flow analysis
6		Object oriented program analysis
7	3 Code generation	Storage mapping
		Run-time stack, calling sequence
8		Translation of control structures
9		Code selection by tree pattern matching
10, 11	4 Register allocation	Expression trees (Sethi/Ullman)
		Basic blocks (Belady)
		Control flow graphs (graph coloring)
12	5 Code Parallelization	Data dependence graph
13		Instruction Scheduling
14		Loop parallelization
15	Summary	

## References

Course material:

**Compilation Methods:** <http://ag-kastens.upb.de/lehre/material/compil>

**Programming Languages and Compilers:** <http://ag-kastens.upb.de/lehre/material/plac>

Books:

U. Kastens: **Übersetzerbau**, Handbuch der Informatik 3.3, Oldenbourg, 1990; (sold out)

K. Cooper, L. Torczon: **Engineering A Compiler**, Morgan Kaufmann, 2003

S. S. Muchnick: **Advanced Compiler Design & Implementation**,  
Morgan Kaufmann Publishers, 1997

A. W. Appel: **Modern Compiler Implementation in C**, 2nd Edition  
Cambridge University Press, 1997, (in Java and in ML, too)

W. M. Waite, L. R. Carter: **An Introduction to Compiler Construction**,  
Harper Collins, New York, 1993

M. Wolfe: **High Performance Compilers for Parallel Computing**, Addison-Wesley, 1996

A. V. Aho, M. S. Lam, R. Sethi, J. D. Ullman: **Compilers - Principles, Techniques, & Tools**,  
2nd Ed, Pearson International Edition (Paperback), and Addison-Wesley, 2007

# Course Material in the Web: HomePage

Lecture Compilation Methods SS 2013

ag-kastens.upb.de/lehre/material/compil/index.html

UNIVERSITÄT PADERBORN  
Die Universität der Informationsgesellschaft

Fachgruppe Kastens > Lehre > Compilation Methods SS 2013

**Lecture Compilation Methods SS 2013**

Slides	Assignments
<ul style="list-style-type: none"> <li>Chapters</li> <li>Slides</li> <li>Printing</li> </ul>	<ul style="list-style-type: none"> <li>Assignments</li> <li>Printing</li> </ul>
Organization	Ressources
<ul style="list-style-type: none"> <li>General Information</li> <li>News</li> </ul>	<ul style="list-style-type: none"> <li>Objectives</li> <li>Literature</li> <li>Contents <i>Kastens: Übersetzerbau</i></li> <li>Internet Links</li> <li>Material: Programming Languages and Compilers</li> </ul>

Veranstaltungs-Nummer: L.079.05810

Generiert mit Camelot | Probleme mit Camelot? | Geändert am: 19.02.2013

# Course Material in the Web: Organization

Lecturer	Examination
<p><b>Prof. Dr. Uwe Kastens:</b></p> <p><b>Office hours</b></p> <ul style="list-style-type: none"> <li>Wed 16.00 - 17.00 F2.308</li> <li>Thu 11.00 - 12.00 F2.308</li> </ul>	<p>This course is examined in an oral examination, which in general is held in English. It may be held in German, if the candidate does not need the certificate of an English examination.</p> <p>In the study program Master of Computer Science the examination for this course is part of a module examination which covers two courses. It may contribute to the module examination of one of the modules III.1.2 (type A), III.1.5 (type A), or III.1.6 (type B). Please follow the <a href="#">instructions for examination registration</a> or in German <a href="#">zur Prüfungsanmeldung</a></p> <p>In other study programs a single oral examination for this course may be taken.</p> <p>In any case a candidate has to register for the examination in PAUL and has to ask for a date for the exam via eMail to me.</p> <p>The next time spans I offer for oral exams are July 31 to Aug 01, 2013, and Oct 09 to 11, 2013.</p>
Hours	Homework
<p><b>Lecture</b></p> <ul style="list-style-type: none"> <li>V2 Fr 11:15 - 12:45 F1.110</li> </ul> <p><b>Start date:</b> Fr Apr 12, 2013</p> <p><b>Tutorials</b></p> <ul style="list-style-type: none"> <li>Ü2 Fr 13:15 - 14:45, F1.110, even weeks</li> </ul> <p><b>Dates:</b> 19.04., 03.05., 17.05., 31.05., 14.06., 28.06., 12.07.</p>	<p><b>Homework assignments</b></p> <ul style="list-style-type: none"> <li>Homework assignments are published every other week on Fridays.</li> </ul>

## Compiler Structure and Interfaces

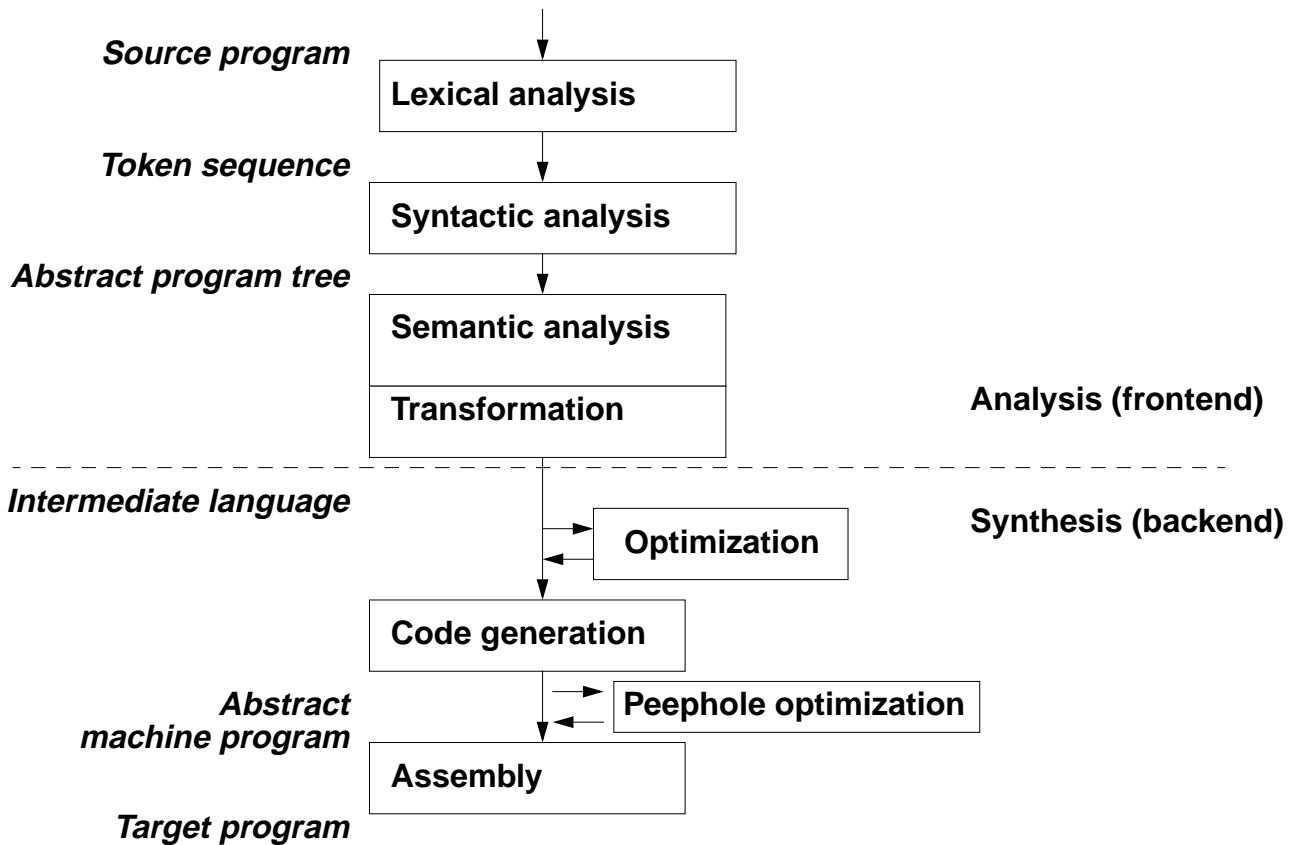

## 2 Optimization

### Objective:

Reduce run-time and / or code size of the program,  
**without changing its observable effects.**  
 Eliminate redundant computations, simplify computations.

**Input:** Program in intermediate language

**Task:** find redundancies (**analysis**)  
 improve the code (**optimizing transformations**)

**Output:** Improved program in intermediate language

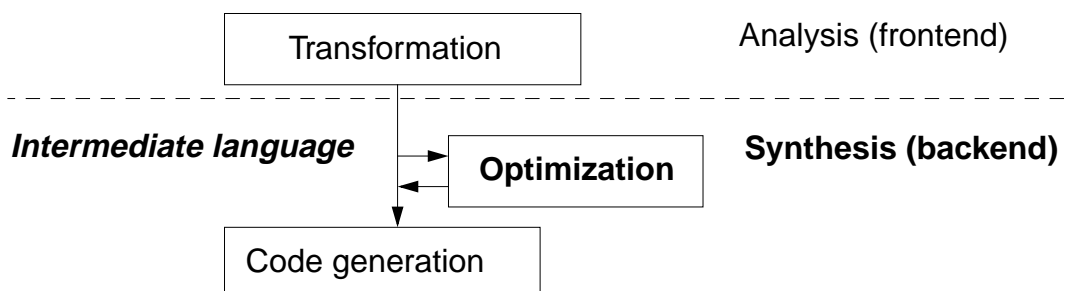

## Overview on Optimizing Transformations

Name of transformation:

Example for its application:

1. **Algebraic simplification** of expressions

$2 * 3.14 \Rightarrow 6.28$     $x+0 \Rightarrow x$     $x*2 \Rightarrow$  shift left    $x**2 \Rightarrow x*x$

2. **Constant propagation** (dt. Konstantenweitergabe)

constant values of variables propagated to uses:

`x = 2; ... y = x * 5;`

3. **Common subexpressions** (gemeinsame Teilausdrücke)

avoid re-evaluation, if values are unchanged

`x = a*(b+c); ... y = (b+c)/2;`

4. **Dead variables** (überflüssige Zuweisungen)

eliminate redundant assignments

`x = a + b; ... x = 5;`

5. **Copy propagation** (überflüssige Kopieranweisungen)

substitute use of x by y

`x = y; ... ; z = x;`

6. **Dead code** (nicht erreichbarer Code)

eliminate code, that is never executed

`b = true; ... if (b) x = 5; else y = 7;`

## Overview on Optimizing Transformations (continued)

Name of transformation:

Example for its application:

7. **Code motion** (Code-Verschiebung)

move computations to cheaper places

`if (c) x = (a+b)*2; else x = (a+b)/2;`

8. **Function inlining** (Einsetzen von Aufrufen)

substitute call of small function by a computation over the arguments

`int Sqr (int i) { return i * i; }`  
`x = Sqr (b*3)`

9. **Loop invariant code**

move invariant code before the loop

`while (b) {... x = 5; ...}`

10. **Induction variables in loops**

transform multiplication into incrementation

`i = 1; while (b) { k = i*3; f(k); i = i+1; }`

## Program Analysis for Optimization

### Static analysis:

**static properties** of program structure and of **every execution**;  
**safe, pessimistic assumptions**  
 where input and dynamic execution paths are not known

### Context of analysis - the larger the more information:

Expression	local optimization
Basic block	local optimization
procedure (control flow graph)	global intra-procedural optimization
program module (call graph) separate compilation	global inter-procedural optimization
complete program	optimization at link-time or at run-time

### Analysis and Transformation:

Analysis provides preconditions for **applicability of transformations**

Transformation may change analysed properties,  
 may **inhibit or enable** other transformations

**Order** of analyses and transformations **is relevant**

## Program Analysis in General

**Program text** is systematically analyzed to exhibit  
**structures** of the program,  
**properties** of program entities,  
**relations** between program entities.

### Objectives:

#### Compiler:

- Code improvement
- automatic parallelization
- automatic allocation of threads

#### Software engineering tools:

- program understanding
- software maintenance
- evaluation of software qualities
- reengineering, refactoring

**Methods** for program analysis stem from **compiler construction**

# Overview on Program Analysis in Compilers

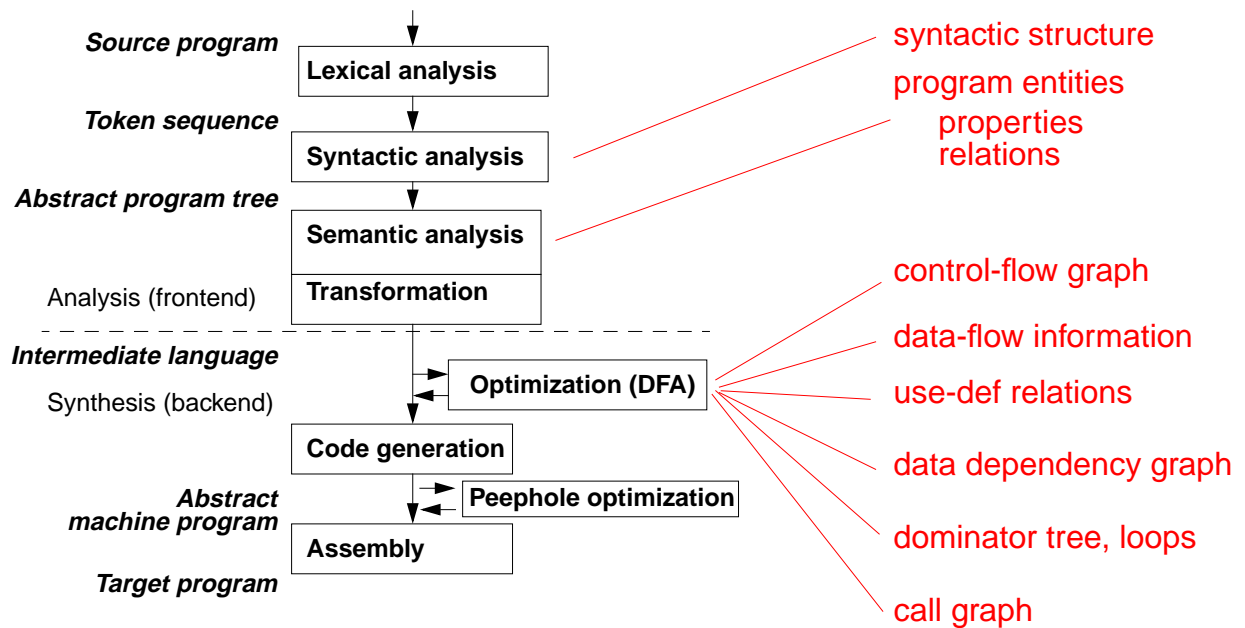

## Basic Blocks

### Basic Block (dt. Grundblock):

Maximal sequence of instructions that can be entered only at the first of them and exited only from the last of them.

### Begin of a basic block:

- procedure entry
- target of a branch
- instruction after a branch or return (must have a label)

### Function calls

are usually not considered as a branch, but as operations that have effects

### Local optimization

considers the context of one single basic block (or part of it) at a time.

### Global optimization:

Basic blocks are the nodes of control-flow graphs.

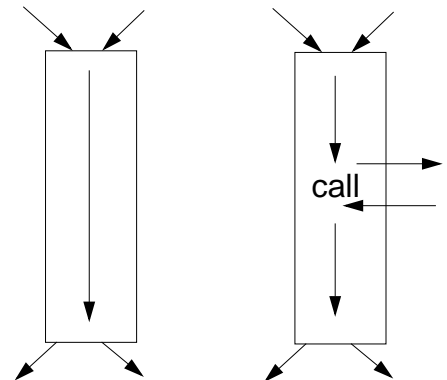

## Example for Basic Blocks

A C function that computes Fibonacci numbers:

```
int fib (int m)
{ int f0 = 0, f1 = 1, f2, i;
  if (m <= 1)
    return m;
  else
  { for(i=2; i<=m; i++)
    { f2 = f0 + f1;
      f0 = f1;
      f1 = f2;
    }
    return f2;
  }
}
```

**if-condition** belongs to the preceding basic block

**while-condition** does not belong to the preceding basic block

Intermediate code with basic blocks:

[Muchnick, p. 170]

1	receive m	
2	f0 <- 0	
3	f1 <- 1	
4	if m <= 1 goto L3	<b>B1</b>
5	i <- 2	<b>B3</b>
6	L1: if i <= m goto L2	<b>B4</b>
7	return f2	<b>B5</b>
8	L2: f2 <- f0 + f1	
9	f0 <- f1	
10	f1 <- f2	<b>B6</b>
11	i <- i + 1	
12	goto L1	
13	L3: return m	<b>B2</b>

## Control-Flow Graph (CFG)

A **control-flow graph, CFG** (dt. Ablaufgraph) represents the control structure of a function

**Nodes:** **basic blocks** and 2 unique nodes **entry** and **exit**.

**Edge a -> b:** control may flow from the end of a to the begin of b

**Fundamental data structure for**

- control flow analysis
- structural transformations
- code motion
- data-flow analysis (DFA)

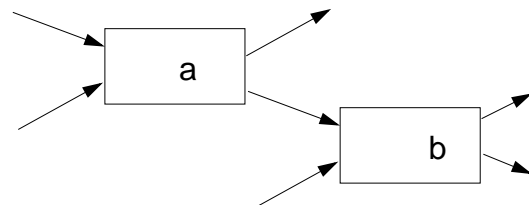



## Example for a Control-flow Graph

Intermediate code with basic blocks:

Control-flow graph:

[Muchnick, p. 172]

1	receive m	<b>B1</b>
2	f0 ← 0	
3	f1 ← 1	
4	if m ≤ 1 goto L3	
5	i ← 2	<b>B3</b>
6	L1: if i ≤ m goto L2	<b>B4</b>
7	return f2	<b>B5</b>
8	L2: f2 ← f0 + f1	<b>B6</b>
9	f0 ← f1	
10	f1 ← f2	
11	i ← i + 1	
12	goto L1	
13	L3: return m	<b>B2</b>

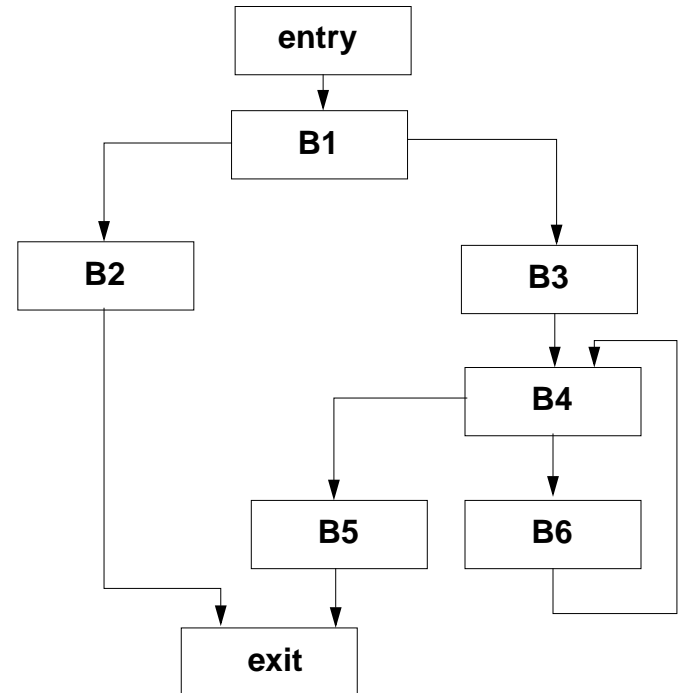

## Control-Flow Analysis

Compute **properties on the control-flow** based on the CFG:

- **dominator relations:**  
properties of paths through the CFG
- **loop recognition:**  
recognize loops - independent of the source language construct
- **hierarchical reduction of the CFG:**  
a region with a unique entry node on the one level is a node of the next level graph

Apply **transformations** based on control-flow information:

- **dead code elimination:**  
eliminate unreachable subgraphs of the CFG
- **code motion:**  
move instructions to better suitable places
- **loop optimization:**  
loop invariant code, strength reduction, induction variables

## Dominator Relation on CFG

Relation over nodes of a CFG, characterizes paths through CFG,  
used for loop recognition, code motion

**a dominates b (a dom b):**

a is on every path from the entry node to b (reflexive, transitive, antisymmetric)

**a is immediate dominator of b (a idom b):**

a dom b and  $a \neq b$ , and there is no c such that  $c \neq a$ ,  $c \neq b$ , a dom c, c dom b.

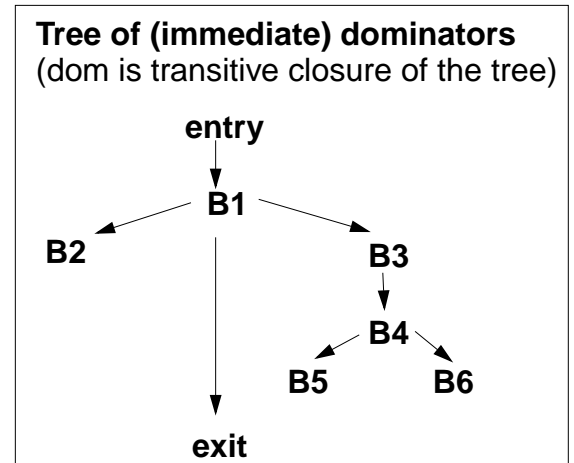
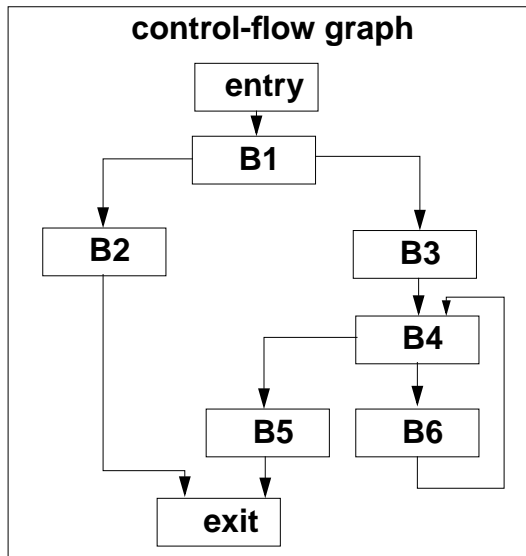

## Immediate Dominator Relation is a Tree

Every node has a unique immediate dominator.

The dominators of a node are linearly ordered by the idom relation.

Proof by contradiction:

Assume:

$a \neq b$ ,  $a \text{ dom } n$ ,  $b \text{ dom } n$  and  
not  $(a \text{ dom } b)$  and not  $(b \text{ dom } a)$

Then there are paths in the CFG

- $p_1$ : from entry to a not touching b, since not  $(b \text{ dom } a)$
- $p_2$ : from entry to b not touching a, since not  $(a \text{ dom } b)$
- $q_1$ : from a to n not touching b, since  $a \text{ dom } n$  and not  $(a \text{ dom } b)$
- $q_2$ : from b to n not touching a, since  $b \text{ dom } n$  and not  $(b \text{ dom } a)$

Hence, there is a path  $p_1$ - $q_1$  from entry via a to n not touching b.

That is a contradiction to the assumption  $b \text{ dom } n$ .

Hence, n has a unique immediate dominator, either a or b.

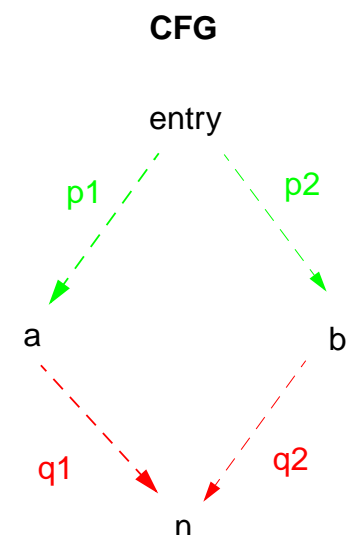

## Dominator Computation

Algorithm computes the sets of dominators  $\text{Domin}(n)$  for all nodes  $n \in N$  of a CFG:

```

for each  $n \in N$  do  $\text{Domin}(n) = N$ ;
 $\text{Domin}(\text{entry}) = \{\text{entry}\}$ ;

repeat
  for each  $n \in N - \{\text{entry}\}$  do
     $T = N$ ;
    for each  $p \in \text{pred}(n)$  do
       $T = T \cap \text{Domin}(p)$ ;
     $\text{Domin}(n) = \{n\} \cup T$ ;
until  $\text{Domin}$  is unchanged
  
```

Symmetric relation for backward analysis:

**a postdominates b (a pdom b):**

a is on every path from b to the exit node (reflexive, transitive, antisymmetric)

## Loop Recognition: Structured Loops

**while (c) stmt;**

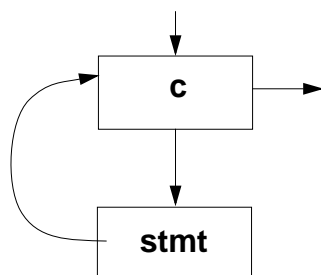

**do stmt; while (c);**

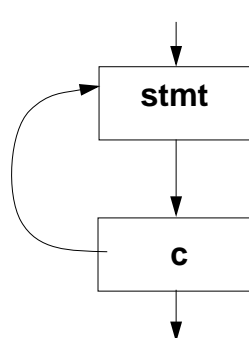

**do s1; if ( )break; s2; while (true);**

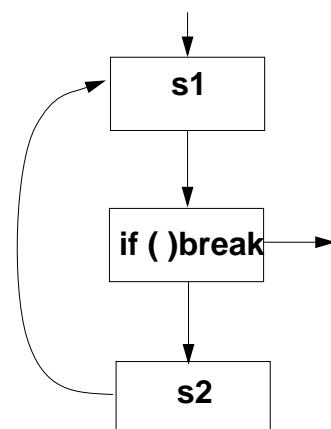

## Loop Recognition: Natural Loops

**Back edge**  $t \rightarrow h$  in a CFG: head  $h$  dominates tail  $t$  ( $h \text{ dom } t$ ).

**Natural loop of a back edge  $t \rightarrow h$ :**

set  $S$  of nodes such that  $S$  contains  $h$ ,  $t$  and  
all nodes from which  $t$  can be reached without passing through  $h$ .  
 $h$  is the **loop header**.

**Iterative computation** of the natural loop for  $t \rightarrow h$ :

add predecessors of nodes in  $S$  according to the formula:

$$S = \{h, t\} \cup \{p \mid \exists a (a \in S \setminus \{h\} \wedge p \in \text{pred}(a))\}$$

This definition of **back edges** is stronger than that of **DFS back edges**:

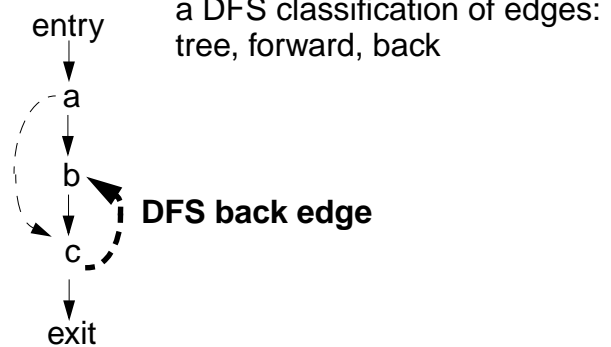
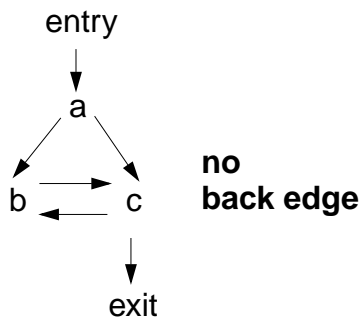

## Example for Loop Recognition

back edge:

4  $\rightarrow$  3

6  $\rightarrow$  2

7  $\rightarrow$  2

6  $\rightarrow$  6

natural loop:

$$S_1 = \{3, 4\}$$

$$S_2 = \{2, 3, 4, 5, 6\}$$

$$S_3 = \{2, 3, 4, 5, 7\}$$

$$S_4 = \{6\}$$

loops are

• **disjoint**

$$S_1 \cap S_4 = \emptyset$$

• **nested**

$$S_1 \subset S_2$$

• **non-nested,**

$$S_2, S_3$$

but have the same loop header,  
are comprised into one loop

back  
edge

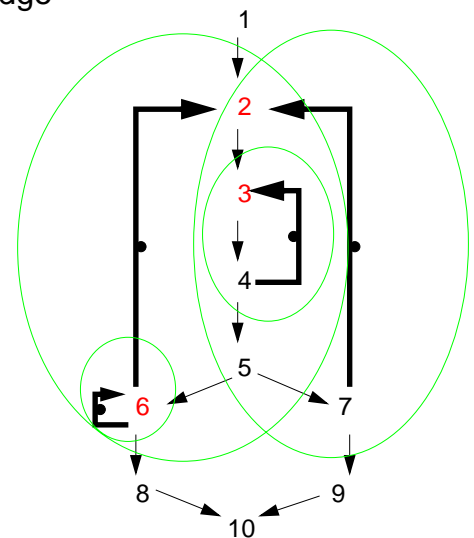

## Loop Optimization

- Introduce a **preheader** for a loop, as a place for loop invariant computations: a new, empty basic block that lies on every path to the loop header, but is not iterated:

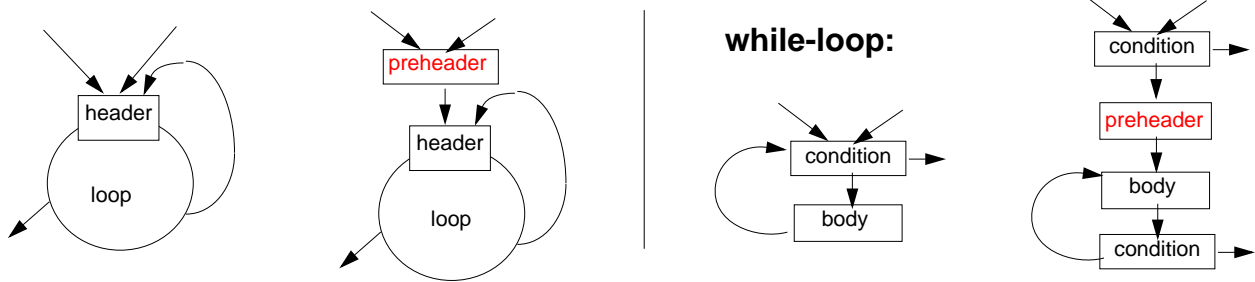

- move **loop invariant computations** to the preheader: check use-def-chains: if an expression  $E$  contains no variables that are defined in the loop, then replace  $E$  by a temporary variable  $t$ , and compute  $t = E$ ; in the preheader.
- eliminate **redundant bounds-checks**: propagate value intervals using the same technique as for constant propagation (see DFA) Example in Pascal:

```
var  a: array [1..10] of integer;
     i: integer;
```

```
for i := 1 to 10 do a[i] := i;
```

- induction variables, strength reduction**: see next slide

## Loop Induction Variables

Induction variables may occur in any loop - not only in `for` loops.

### Induction variable $i$ :

$i$  is incremented (decremented) by a constant value  $c$  on every iteration.

### Basic induction variable $i$ :

There is exactly one definition  $i = i + c$ ; or  $i = i - c$ ; that is executed on every path through the loop.

### Dependent induction variable $j$ :

$j$  depends on induction variable  $i$  by a linear function  $i * a + b$  represented by  $(i, a, b)$ .

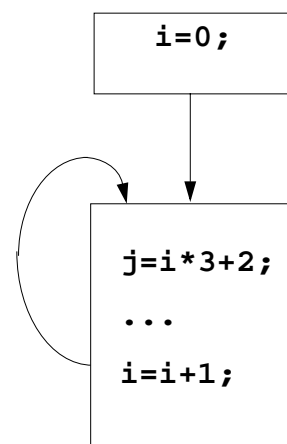

## Transformation of Induction Variables

**Transformation** of dependent induction variables:

1. For each  $(i, a, b)$  create a temporary variable  $s$ .
2. Initialize  $s = i * a + b$ ; in the preheader.
3. Replace  $i * a + b$  in the loop by  $s$ .
4. Add  $s = s + c*a$ ; behind the increment of  $i$

$j: (i, 3, 2)$

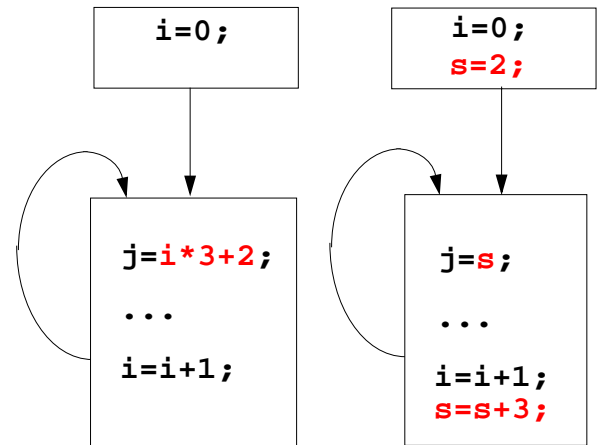

**Strength reduction:**

Replace a costly operation (multiplication) by a cheaper one (addition).

**Linear increment of array address computation (next slide)**

## Examples for Transformations of Induction Variable

```
do
  k = i*3+1;
  f (5*k);
  /* x = a[i]; compiled: */
  x = cont(start+i*elsize);
  i = i + 2;
while (Ek)
```

basic induction variable:

$i: c = 2$

dependent induction variables:

$k: (i, 3, 1)$

$arg: (k, 5, 0)$

$ind: (i, elsize, start)$

```
sk = i*3+1;
sarg = sk*5;
sind = start + i*elsize;
do
  k = sk;
  f (sarg);
  x = cont (sind);
  i = i + 2;
  sk = sk + 6;
  sarg = sarg + 30;
  sind = sind + 2*elsize;
while (Ek)
```