

7. Asynchronous Message Passing

Processes send and receive messages via channels

Message: value of a composed data type or object of a class

Channel: queue of arbitrary length, containing messages

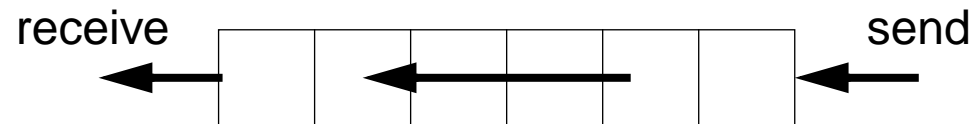

operations on a channel:

- **send (b):** adds the message **b** to the end of the queue of the channel; does **not block** the executing process (in contrast to synchronous send)
- **receive():** yields the oldest message and deletes it from the channel; **blocks** the executing process as long as the channel is empty.
- **empty():** yields true, if the channel is empty; the result is **not necessarily up-to-date**.

send and **receive** are executed under mutual exclusion.

Channels implemented in Java

```

public class Channel
{
    // implementation of a channel using a queue of messages
    private Queue msgQueue;

    public Channel ()
        { msgQueue = new Queue (); }

    public synchronized void send (Object msg)
        { msgQueue.enqueue (msg); notify(); } // wake a receiving process

    public synchronized Object receive ()
        {
            while (msgQueue.empty())
                try { wait(); } catch (InterruptedException e) {}
            Object result = msgQueue.front(); // the queue is not empty
            msgQueue.dequeue();
            return result;
        }

    public boolean empty ()
        { return msgQueue.empty (); }
}

```

All waiting processes wait for the same condition => notify() is sufficient.

After a notify-call a new receive-call may have stolen the only message => wait loop is needed

Processes and channels

link:

one sender is connected to **one receiver**;
e. g. processes form chains of
transformation steps (pipeline)

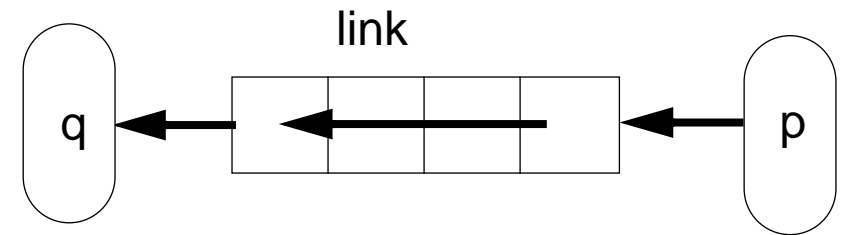

input port of a process:

many senders - one receiver;
channel belongs to the receiving process;
e. g. a server process receives tasks
from several client processes

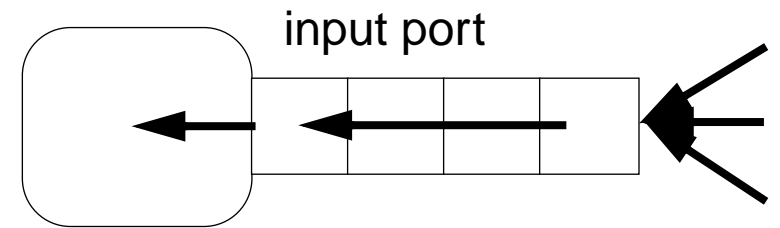

output port of a process:

one sender - many receivers;
channel belongs to the sending process;
e. g. a process distributes tasks to many servers
(unusual structure)

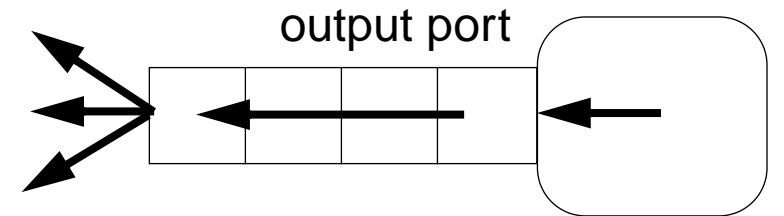

pair of request and reply channels;

one process requests - the others replies;
tight synchronization,
e. g. between client and server

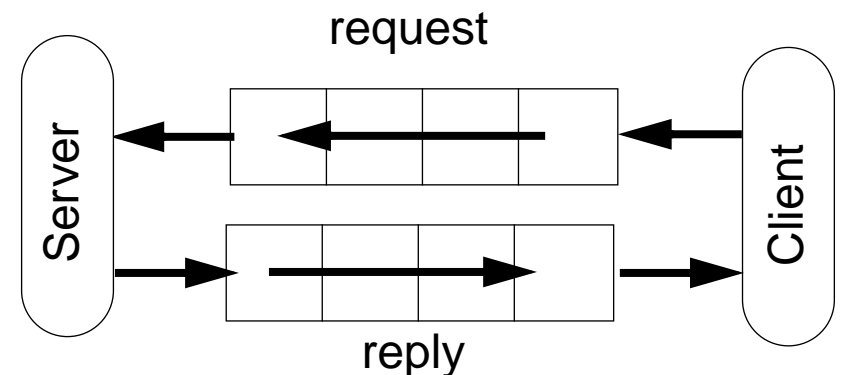

Termination conditions

When system of processes terminates the following **conditions** must hold:

1. **All channels are empty.**
2. **No** processes are **blocked on a receive** operation.
3. **All** processes are **terminated**.



Otherwise the **system state is not well-defined**, e.g. task is not completed, some operations are pending.

Problem:

In general, the processes **do not know the global system state**.

Message structures

A **message object** may have arbitrary structure suitable for the **particular purpose**:

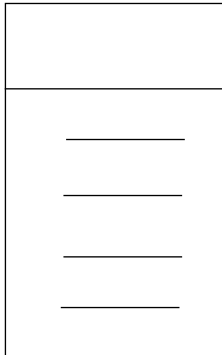
	empty	synchronization only
	kind	different kinds of messages, without data e. g. signal different kinds of events
	kind argument vector	different kinds of messages with data e. g. number and or identities of resources special case: a channel on which the sender expects a reply

Operations on messages:

constructors

setKind (k), getKind ()

setArg (ind, val), getArg (ind), getArgList ()

Client / server: basic channel structure

One server process responds to requests of several client processes

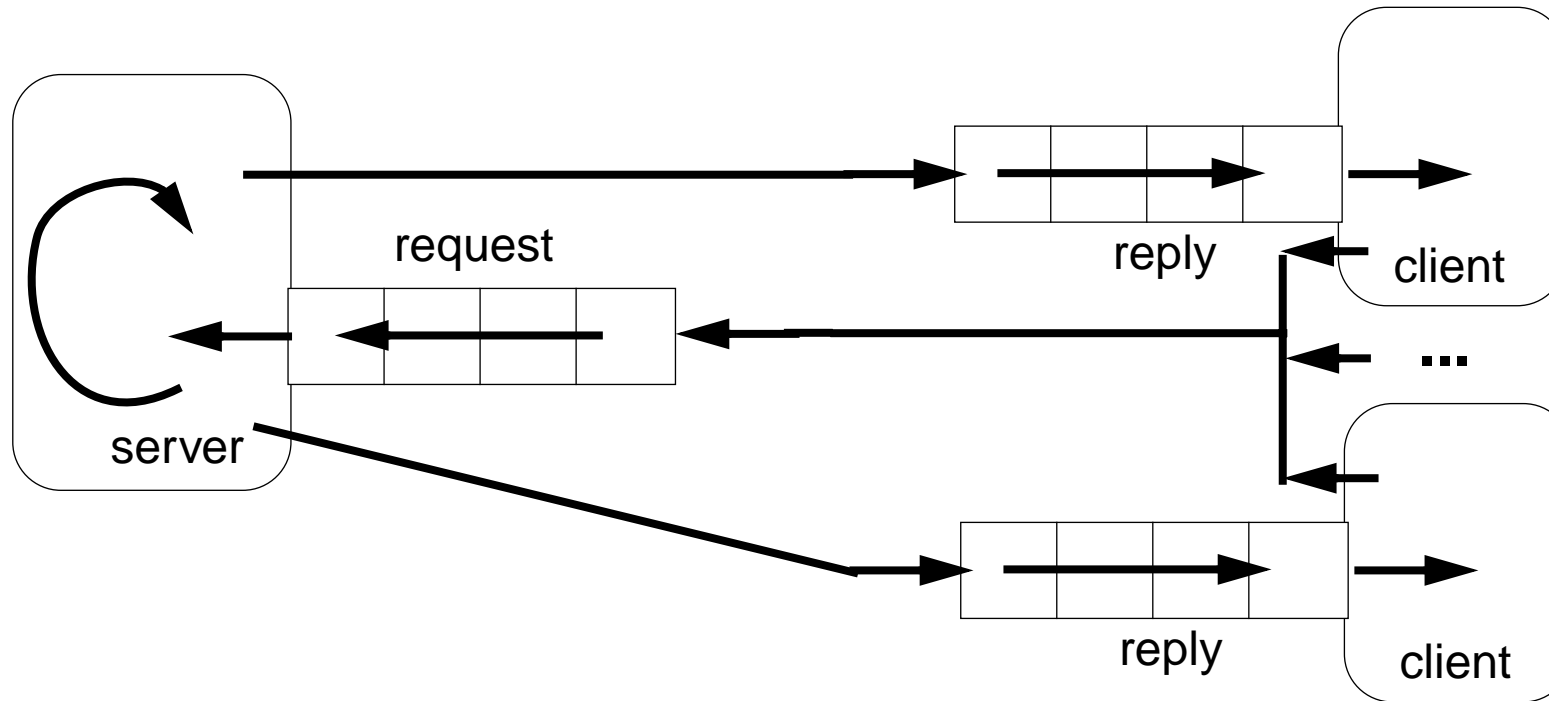

request channel:

input port of the server

reply channel:

one for each client (input port),
may be sent to the server included in the request message

Application: server distributes data or work packages on requests

Server processes: different kinds of operations

Different requests (operations) are represented by different **kinds of messages**.

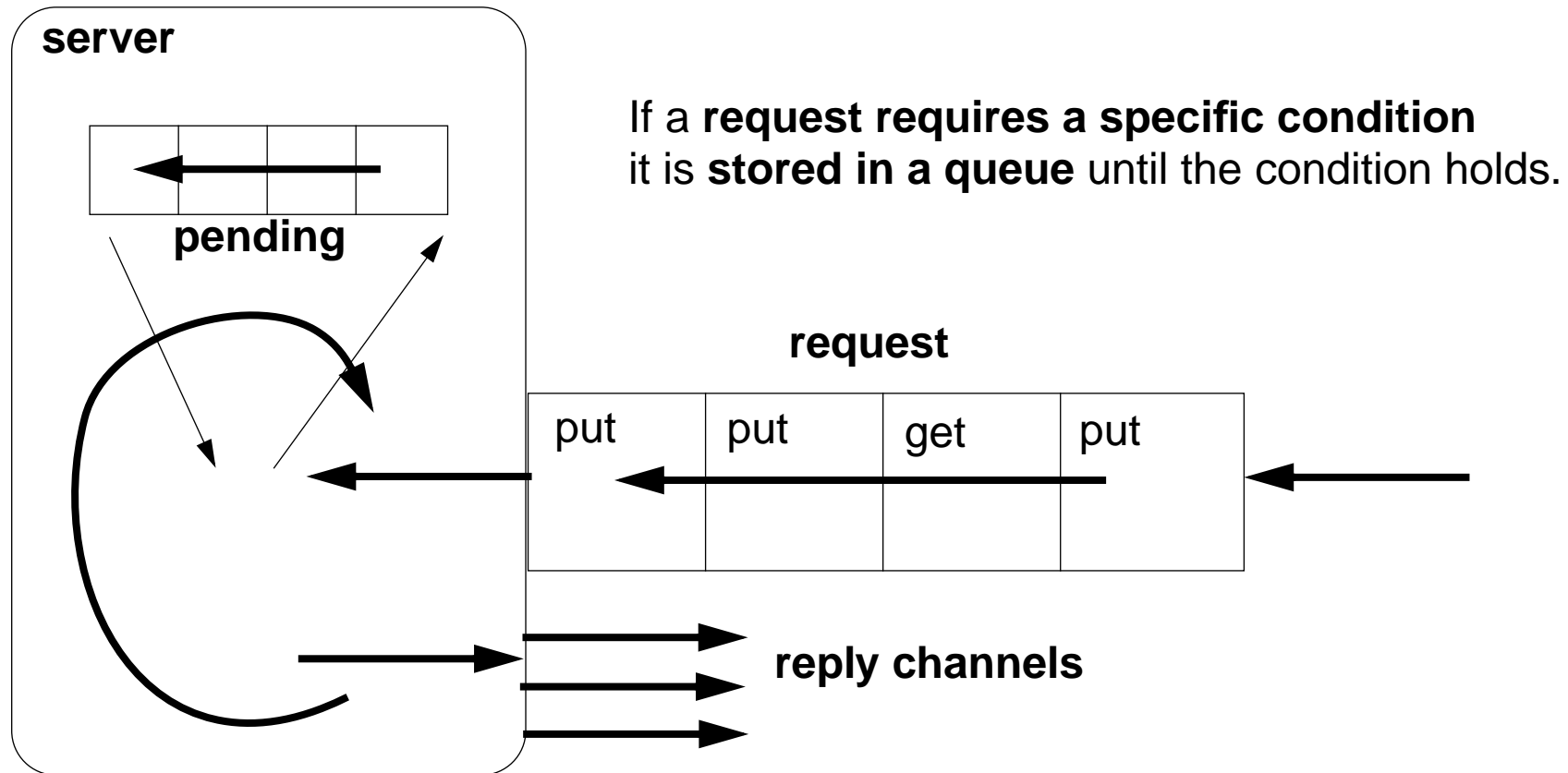

The server processes the requests **strictly sequentially**;
thus, it is guaranteed that critical sections are **not executed interleaved**.

Termination: terminate clients, empty channel, empty queue.

Different kinds of operations on different channels

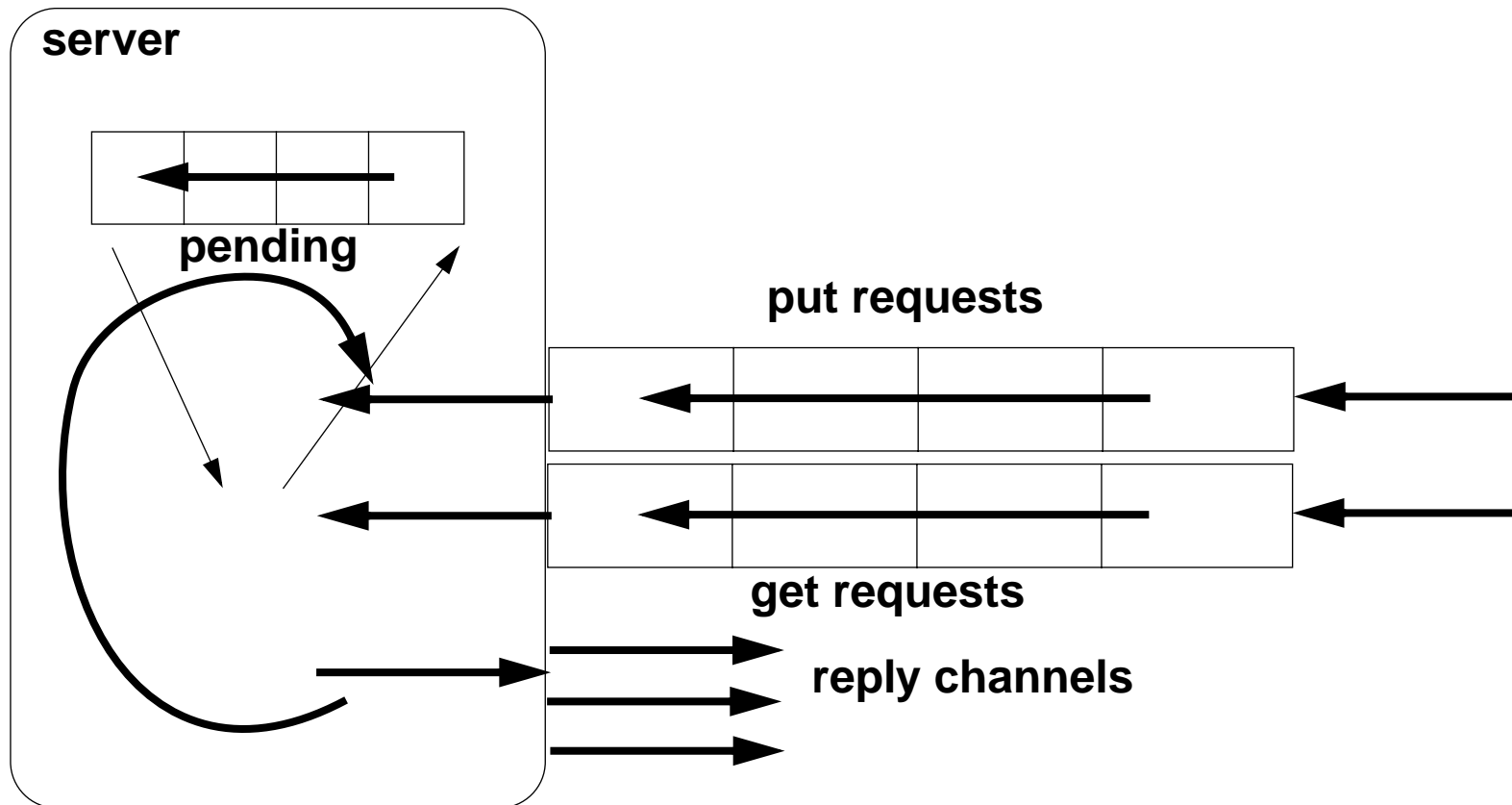

Server must not block on an empty input port while another port may be non-empty:

```
while (running) {
    if (!putPort.empty()) { msg = putPort.receive(); ... }
    if (!getPort.empty()) { msg = getPort.receive(); ... }
    if (!pending.empty()) { msg = pending.dequeue(); ... }
}
```

Several servers

Several server processes, several client processes, several request channels

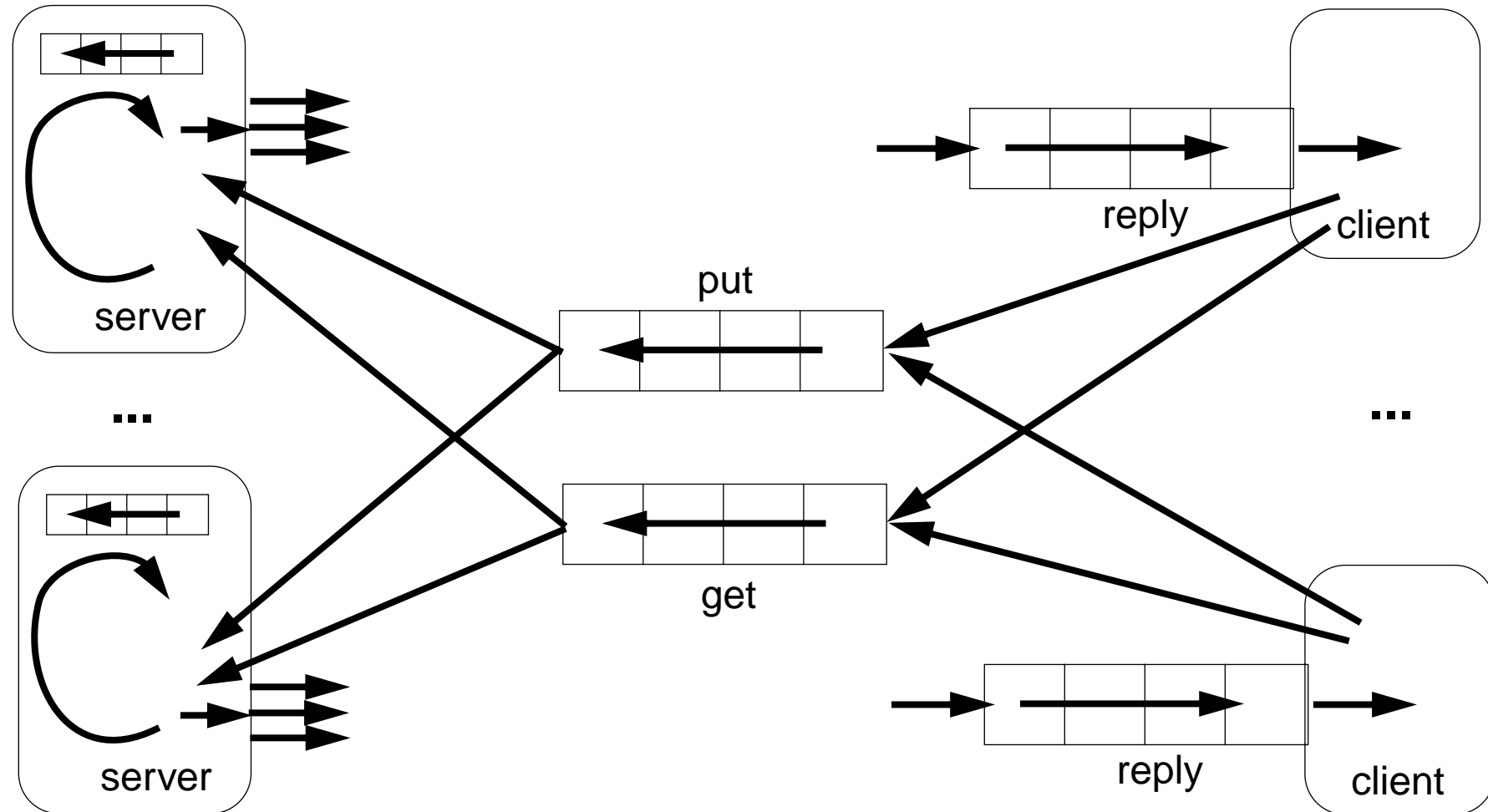

Termination: empty request channels, empty queues, empty reply channels

Caution: a receive on a channel may block a server!

Receive without blocking

If several processes receive from a channel `ch`, then the check

```
if (!ch.empty()) msg = ch.receive();
```

may block.

That is not acceptable when several channels have to be checked in turn.

Hence, a new non-blocking channel method is introduced:

```
public class Channel
{
    ...
    public synchronized Object receiveMsgOrNull ()
    {
        if (msgQueue.empty()) return null;
        Object result = msgQueue.front();
        msgQueue.dequeue();
        return result;
    }
}
```

Checking several channels:

```
while (msg == null)
{
    if ((msg = ch1.receiveMsgOrNull()) == null)
        if ((msg = ch2.receiveMsgOrNull()) == null)
            Thread.sleep (500);
}
```

Conversation sequences between client and server

Example for an **application pattern** is „file servers“:

- **several equivalent servers** respond to requests of **several clients**
- a client sends an **opening request** on a **channel common** for all servers (**open**)
- one server commits to the task; it then leads a conversation with the client according to a **specific protocol**, e. g.
(open openReply) ((read readReply) | (write writeReply))* (close closeReply)
- **reply channels** are contained in the **open** and **openReply** messages.

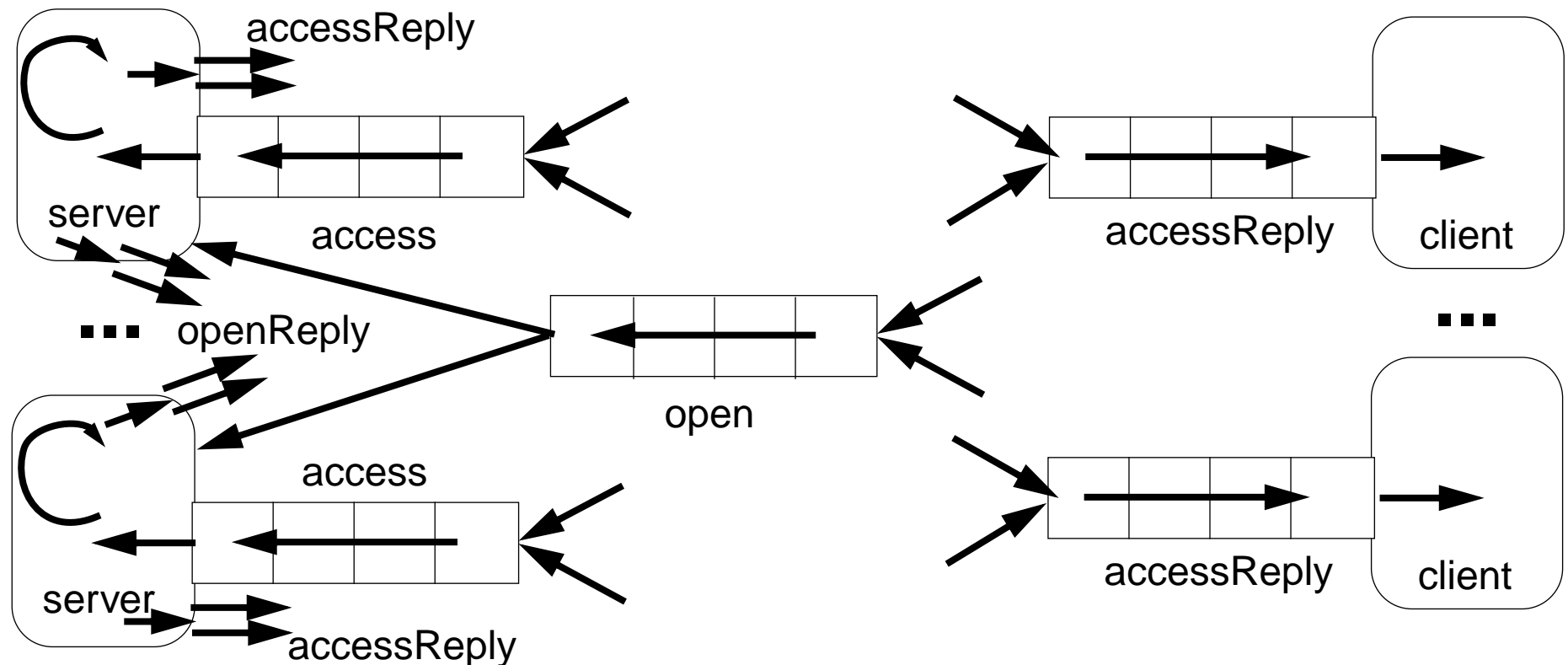

Active monitor (server) vs. passive monitor

active monitor

active process

request - reply via channels

kinds of messages and/or
different channels

requests are handled
sequentially

queue of pending requests
replies are delayed

may cooperate on the
same request channels

1. program structure

2. client communication

3. server operations

4. mutual exclusion

5. delayed service

6. multiple servers

passive monitor

passive program module

calls of entry procedures

entry procedures

guaranteed for entry procedure
calls

client processes are blocked
condition variables, wait - signal

multiple monitors are not related